

## OSG HS

19900

Ø 300 mm  
2,00-3,00 m/s  
Halat Çapı Ø 6,0-6,5-8,0 mm

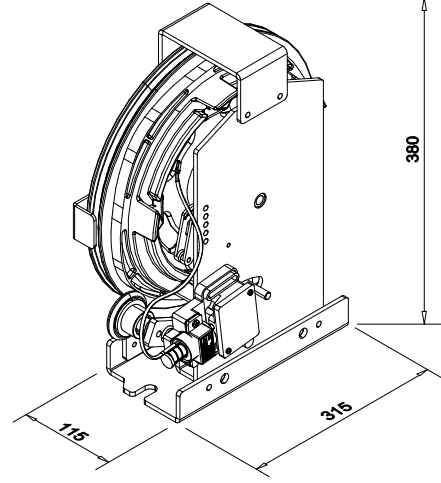

EN 81:20  
EN 81:50

### EN 81:20 ve EN 81:50 Asansör direktiflerine uygun aşağı ve yukarı yönde frenleme

*Fulfillment of lift directive EN 81:20 and EN 81:50 engaging of the safety gear in both directions.*

### EN 81:20 ve EN 81:50 gereğince önce güvenlik kontağını keser daha sonra frenler

*First cuts off the safety switch and then trips.*

### Makine Dairesi ve Kuyu içine montaj edilebilir

*Configuration for machine room or shaft head possible*

### Emniyet kontaklı gergi kasnağı

*Overspeed governor with safety contact. Tensioning weight with safety contact*

### Revizyon ve modernizasyon için kullanılabilir

*Applicable for secondary installations and modernizations*

### Nominal hızlara göre ayarlanıp mühürlenmiştir

*Pre-set according to nominal speeds and sealed*

### Bağlantı delikleri diğer hız regülatörlerine uygundur

*Fixing holes are completely compatible with other overspeed governors*

### Hidrolik ve Elektrikli Asansörlere uygundur

*Mounting at almost every lift type possible*

### Montajı kolaydır, bakım gerektirmez

*Easy installation and maintenance. Detailed operating instructions*

### Opsiyonel uzaktan kontrol sistemi, encoder ve UCM bobin uygulanır.

*Optional remote-control unit, encoder and UCM coil*

### En 81-20 – 50 standartları madde 5.6.2.2.1.1 belirtildiği üzere regülatör frenleme hızı beyan hızının min %115 ine eşit olması genel bir kural olarak bilinmesine rağmen standartta bu maddelerde belirtilmektedir.

*As mentioned in the en 81-20 - 50 standards article 5.6.2.2.1.1 the overspeed governor brake speed should be equal min 115% to the stated speed but this article is not mentioned in the rules of the standards*

### Makara tipi hariç, kaydırmaz frenler max 0.80 m/s de frenlemelidir

*Except roller type, instantaneous safety gear should brake at max 0.80m/s*

### Makara tip kaydırmaz frenler max 1.00 m/s de frenlemelidir

*Roller type instantaneous safety gear should brake at max 1.00 m/s*

### Nominal hızı 1.00m/s olan kaydırmalı frenlerde max 1.50 m/s de frenlemelidir

*For progressive safety gears with nominal speed 1.00 m/s it should brake at max 1.50 m/s*

### Nominal hızı 1.00m/s olan kaydırmalı frenlerde max $1.25 \cdot v + (0.25 / v)$ formülü ile frenleme hızı tespit edilmelidir.

*For progressive safety gears with nominal speed 1.00 m/s the brake speed should be determined by the formula  $max 1.25 \cdot v + (0.25 / v)$*

## OPSİYONEL PARÇALAR | OPTIONAL COMPONENT

EN 81:20  
EN 81:50

### UZAKTAN KONTROL

### REMOTE CONTROL (MRL SYSTEM)

İtme, çekme gücü : 0,85 kg

*Driving power, tractive force: 0,85 kg*

Frenleme bobini 220 V, 0.52 amp ( Kablo mavi renk - 8M Kare diyot ), 354 ohm - 24 V, 8.05 amp ( Kablo sarı renk )

*Tripping coil 220 V, 0.52 amp ( blue colour cable - 8M square diode ), 354 ohm - 24 V, 8.05 amp ( yellow colour cable )*

Kablolarla klemens ile bağlantı

*Connectivity to cables with connector*

190 VDC bobinleri daha güçlü, akım kayıplarından daha az etkilendiği ve enerjili kalma süresi daha uzun olduğu için firmamız önermektedir.

*190 VDC coils are more powerful, less influenced from the current loss and energy time is longer therefore they are recommended by our company.*



**OSG HS**  
**25 KG YANDAN AĞIRLIK GERGİ KASNAĞI**  
*SIDE WEIGHT TENSION PULLEY WITH 25 KG*

Ø300 mm

19470

Halat çapı Ø 6-6,5 mm  
Rope Diameter Ø 6-6,5 mm

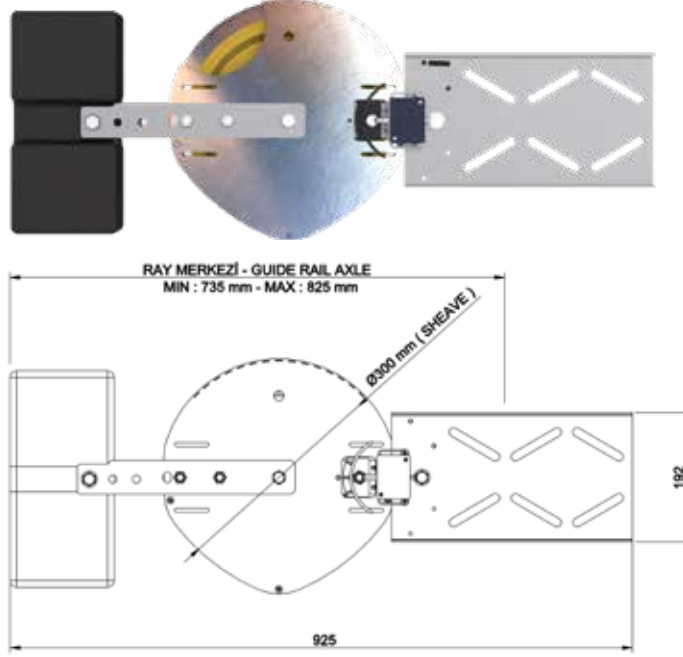

25 KG AĞIRLIK  
WEIGHT 25 KG

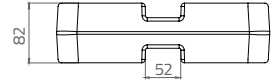
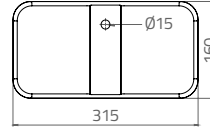

GERGİ KASNAĞI REGÜLATÖRLERİ  
TENSION PULLEY FOR OSG



OSG HS

**KOLİ BİLGİLERİ | PACKING INFORMATION**

ÜRÜN KODU PRODUCT CODE	KASNAK ÇAPI SHEAVE DIAMETER (mm)	EN WIDTH (cm)	BOY LENGHT (cm)	YÜKSEKLİK HEIGHT (cm)	AĞIRLIK WEIGHT (kg)
19470	Ø 300	34	88	12	9

EN 81:20  
EN 81:50